

Data Sheet

Measuring System “autarkon®“ EBR 101M DP Transmitter with Calculation Unit in Microprocessor Technology



Compact and innovative solution for your flow metering tasks
Based on the classic pressure differential principle

Application

Flow and heat metering for gases, steam and liquids.
Can be combined with any current pressure differential devices.



Transmitter DT 311 / DT 312



Calculation unit EBR 101 E



Pt 100/1000 sensor

Special Features

- Can be combined with any current pressure differential sensors
- Measuring system can be optimized for the respective operating data
- Automatic correction of the flow coefficient and the expansion factor
- Compact, highly integrated static measuring system
- Wetted parts in stainless steel
- Modular design
- With pressure and temperature compensation
- With integrated zero-balancing module, thus zero and long-term stable
- Large turn down at high accuracy
- Mostly maintenance-free
- Minimum installation effort due to the integration of differential and absolute pressure transducers into one device

General

The EBR 101M consists of:

- Pressure differential transducer DT 311/312
- Hydraulic zero-balancing module
- integrated absolute pressure transducer (option)
- 3-way shut-off valve module (option)
- Temperature sensor Pt 100/1000 with immersion pocket
- Flow meter / heat meter EBR 101 E with multi-functional LC Display
- Differential pressure sensors like standard orifice plate, nozzle, Venturi tube etc. (options)

The EBR 101M can be applied in all industrial as well as energy producing and distributing branches. All relevant units can be made visible via a multi-functional LC Display. In addition, they can be forwarded to remote stations via standardized current or contact outputs. The EBR 101M can be networked via its built-in M-Bus interface according to EN 1434-3.

Measuring arrangement

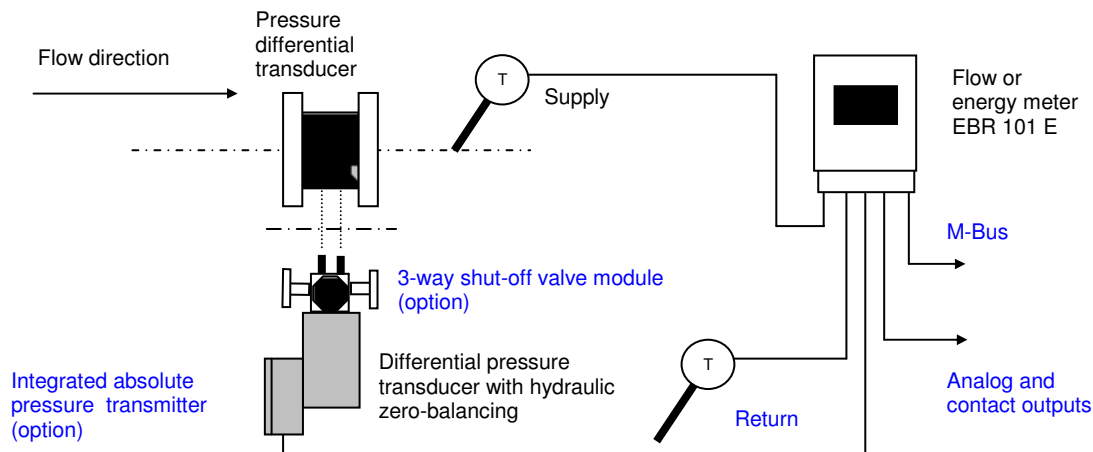

Functional principle and application

The measuring system can be combined with any differential pressure transducers already installed at site. Thus, the original turn down can often be tripled while keeping a high measuring accuracy.

The EBR 101M can be adapted to orifice plates, nozzles and dynamic pressure probes with minimum effort.

The continuous reading of pressure, temperature and differential pressure permit a steady, correct determination of medium density, flow coefficient and expansion factor.

The zero level of the differential pressure cell is automatically balanced. This results in maximum accuracy even at the lowest possible medium flow levels. The measuring system calibrates itself continuously, keeping the zero level stable for years.

As an option, a pressure transducer can be integrated into the differential pressure transducer in order to record the static pressure in compressible fluids (tandem transmitter).

In the calculation unit, the differential pressure which is proportional to the velocity, the pressure and the temperature of the medium are calculated into a mass or volume flow or in an energy quantity, respectively.

Modular design

Can be combined with all current pressure differential transducers

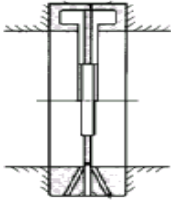

Orifice plate

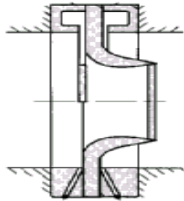

Nozzle

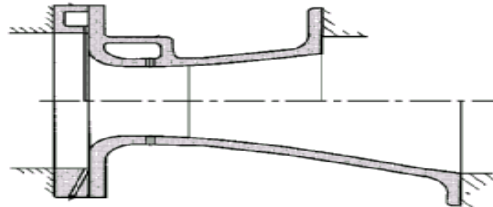

Venturi tube

as well as dynamic pressure probe, V-Cone, quarter-circle nozzle etc.

Transducer DT 311 / DT 312



- ← Oval adapter with Swagelok fitting
- ← 3-way shut-off valve module (option)
- ← Zero-balancing module
- ← Differential pressure transducer
Absolute pressure transducer (option))

Calculation unit EBR 101 E



Flow: $q = f (\alpha, \epsilon, d_t, \Delta p, \rho)$

- α = Flow coefficient (function of Reynolds´ number, orifice ratio, velocity of approach factor)
- ϵ = Expansion factor (function of pressure ratio, isentropic exponent)
- d_t = Damper diameter (function of medium temperature, expansion coefficient)
- Δp = Differential pressure (function of velocity, fluid density, orifice ratio)
- ρ = Density (function of fluid pressure and temperature)

Technical Data EBR 101M

Nominal pressure	PN 63
Operating temperature	Up to 500 °C
Material	Wetted parts in stainless steel (1.4571 / 1.4581)
Fluid	Non-combustible gases, steam, liquids
DT 311 Measuring range	0.8 mbar – 600 mbar
Measuring uncertainty *	0.1 % relative to actual value + 0.05 mbar (enveloping curve)
DT 312 Measuring range	3.2 mbar – 2000 mbar
Measuring uncertainty *	0.15 % relative to actual value + 0.2 mbar (enveloping curve)
Admissible ambient temperature	Transducer DT 311 / DT 312 4 - 55 °C, calculation unit 4 -50 °C
Protection class	Transducer DT 311 / DT 312 IP 65, calculation unit IP 54
Multi-functional LC display integrated in calculation unit EBR 101 E	alphanumeric for P (kW), m (t/h), V (m³/h), tw (°C), tk (°C), energy (kWh), mass (t), standard volume (Nm³) and volume (m³), other units see operator's guide
Temperature input	Pt 100/1000 (four-wire, passive)
Output	Fault indication, crawl flow contact
Weight	6 kg
Power supply	230 V AC, power consumption 15VA, 24V DC (option)
Connection to DT 311/ DT 312	Oval adapter with Swagelok fitting 12 x 1,5mm
Test certificate	3 measuring points for differential pressure
* The data mentioned above relate to the enveloping curve. The actually measured uncertainties are lower as documented in the test certificate. By selection of the transducers, the uncertainties can be further reduced (extra price).	

Additional Equipment

4 floating outputs 0(4) – 20 mA can be freely assigned to any of the actual values; Calibration current for the adjustment of external displays, tracers etc. Voltage-free contacts for volume and energy as well as limit contacts
2 floating outputs 0(4) – 20 mA can be freely assigned to any of the actual values; Calibration current for the adjustment of external displays, tracers etc. Voltage-free contacts for volume and energy as well as 2 limit contacts
1 floating output 0(4) – 20 mA can be freely assigned to any of the actual values; Calibration current for the adjustment of external displays, tracers etc. Voltage-free contacts for volume and energy
3-way shut-off valve module mounted to the transducer
Integrated absolute pressure transducer 0-16 / 25 / 40 bara
Pt 1000 temperature sensor including immersion pocket type 160 (type 75)
Pt 100 temperature sensor including immersion pocket type 160 (type 75)
Immersion pocket type 200
Welding-type immersion pocket type 200, solid material, stainless or creep-resistant steel
Sensor connection cable 4-wire, screened
M-BUS interface
External absolute pressure transducer 0-16 / 25 / 40 bara
8 digit remote counter, controlled by voltage-free contacts
Optoelectronic coupler outputs
Pulse input board
Fault indication counters for energy and mass (volume)
Additional counters for energy and mass (volume) only in combination with pulse input board
Power supply 24 V DC / AC
DT 311P / DT 312 P version „precision“ (only available in combination with zero-balancing module)
Test certificate for 10 flow data points (basis: pressure differential)
System test, commissioning and instruction by METRA service personnel

Error limits**Pressure differential transmitter DT 311 / DT 312**

DT 311: Turn down range 0 – 600 mbar,
Measuring uncertainty in the range between 0.8 – 600 mbar:
 $F_{DT} [\text{mbar}] = \pm (\text{current value} [\text{mbar}] \times 0.1\% + 0.05 \text{ mbar})$

$$F_{DT} [\%] = (F_{DT} [\text{mbar}] / \text{current value} [\text{mbar}]) \times 100\%$$

DT 312: Turn down 0 – 2000 mbar,
Measuring uncertainty in the range between 3.2 – 2000 mbar:
 $F_{DT} [\text{mbar}] = \pm (\text{current value} [\text{mbar}] \times 0.15 + 0.2 \text{ mbar})$

$$F_{DT} [\%] = (F_{DT} [\text{mbar}] / \text{current value} [\text{mbar}]) \times 100\%$$

Calculation Unit EBR 101 E

Measuring uncertainty calculation unit: $F_R = \pm 0.1\%$

Mathematical measuring uncertainty: $F_{RM} = \pm 0.15\%$

For special fluids an analysis of the error relative to the fluid can be applied

Integrated absolute pressure transmitter (compressible media)

Measuring uncertainty absolute pressure transducer: $F_P = \pm 0.5\%$ of end value (nominal value)

Temperature sensor Pt 100 / Pt 1000

1/3 DIN B temperature range –70 °C to 250 °C

$$F_{TK} [^\circ\text{C}] = \pm (0.1 [^\circ\text{C}] + 0.0017 \times I \text{ Fluid temperature } I [^\circ\text{C}])$$

$$F_T [\%] = (F_{TK} [^\circ\text{C}] / I \text{ Fluid temperature } I [^\circ\text{C}]) \times 100\%$$

Class A Sensor temperature range –200 °C to 600 °C

$$F_{TK} [^\circ\text{C}] = \pm (0.15 [^\circ\text{C}] + 0.002 \times I \text{ Fluid temperature } I [^\circ\text{C}])$$

$$F_T [\%] = (F_{TK} [^\circ\text{C}] / I \text{ Fluid temperature } I [^\circ\text{C}])$$

Overall measuring uncertainty F [%] for EBR 101M without pressure differential deviceMeasuring uncertainty for water

$$F_W \approx \sqrt{(F_{DT}/2)^2 + F_R^2 + F_{RM}^2 + (F_T/20)^2}$$

Measuring uncertainty for gaseous fluid (ideal gases) and steam (dry, saturated steam)

$$F_{G,D} \approx \sqrt{(F_{DT}/2)^2 + F_R^2 + F_{RM}^2 + (F_P/2)^2 + (F_T/4)^2}$$

Measuring uncertainty for differential pressure transmitters without wet calibration

Approximate value for uncertainty for classic pressure differential transmitters (only applicable for standardized design or standardized mounting according to ISO 5176)

Orifice plate :	approx. 0.8 %
Nozzle:	approx. 1 %
Standard Venturi nozzle:	approx. 1 %
Venturi tube:	approx. 0.75 – 1.5 % dependent of design

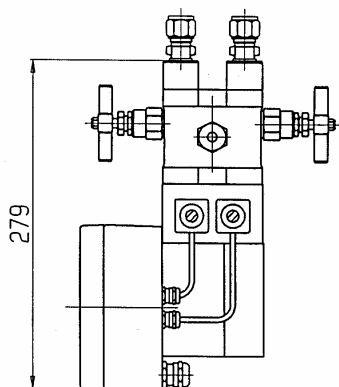
Dimensions**Transducer DT 311 / 312**

Calculation unit EBR 101 E

Wall mounting

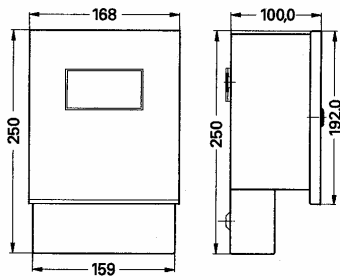

Panel mounting

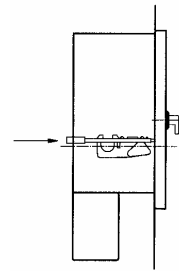
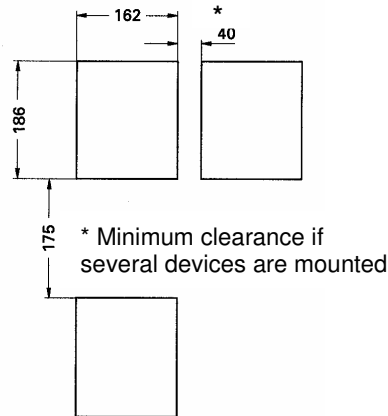

Installation kit for panel mounting

Temperature sensor with immersion pocket

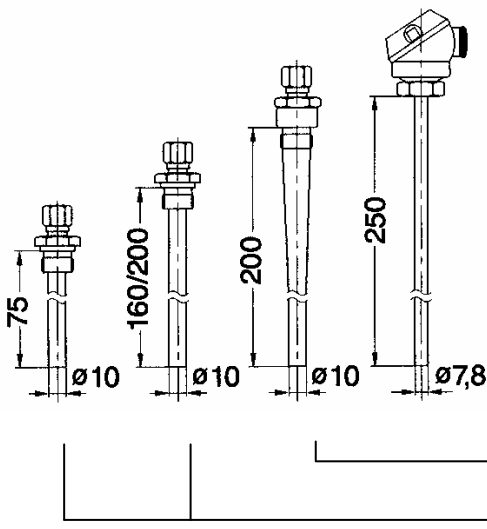

- Type 75 fitting G 1/2"
- Type 160 fitting G 1/2"
- Type 200 fitting G 1/2"
- Type 200 Welding-type immersion pocket fitting G 1/2"

Connection thread according to DIN 2999

- Welding-type immersion pocket
- Screw-type immersion pocket

DP Transmitter with calculation unit “autarkon®“ EBR 101M in Microprocessor Technology

Text for quotations and orders:

Orifice plate-based meter “autarkon“ **EBR 101M** in microprocessor technology consisting of:
Pressure differential transmitter ... orifice plate, nozzle, Venturi nozzle etc.

DN ..., PN ...,

differential pressure ... mbar, nominal flow ...m³/h t/h,

Fluid ..., operating temperature ...°C,

operating pressure ...bara, fitting position vertical / horizontal ...,

flow or heat meter, location of installation cold / warm (in case of liquids)

DT 310 / DT 311 / DT 312 transducer with hydr. zero-balancing for maximum accuracy and long-term stability

DT 310 0 - 100 mbar (PN 25)

DT 311 0 - 600 mbar (PN 64)

DT 312 0 - 2000 mbar (PN 64)

EBR 101 E Calculation unit as flow / heat meter

Power supply 230 V, 50/60 Hz

With automatic compensation of changes in flow coefficient or expansion factor. Automatic correction of temperature ratio of orifice plate as well as pipeline

Multi-functional LC display for m, P, tw, tk, Δt

Electronic counter for (m) in kg or t, energy (E) in kWh or MWh

Output: voltage-free contact for fault indication and crawl flow shut-off,

1 pc Pt 1000 / Pt 100 temperature sensor including immersion pocket type ...,

Test certificate with 3 data points (basis. pressure differential)

Additional Equipment

4 floating outputs 0(4) – 20 mA can be freely assigned to any of the actual values;
calibration current for the adjustment of external displays, tracers etc.
voltage-free contacts for volume and energy as well as 2 limit contacts

2 floating outputs 0(4) – 20 mA can be freely assigned to any of the actual values;
calibration current for the adjustment of external displays, tracers etc.
voltage-free contacts for volume and energy as well as 2 limit contacts

1 floating outputs 0(4) – 20 mA can be freely assigned to any of the actual values;
calibration current for the adjustment of external displays, tracers etc.
voltage-free contacts for volume and energy

3-way shut-off valve module mounted to transducer

Integrated absolute pressure transducer 0-16 / 25 / 40 bara

Pt 1000 temperature sensor including immersion pocket type 160 (type 75)

Pt 100 temperature sensor including immersion pocket type 160 (type 75)

Immersion pocket type 200

Welding-type immersion pocket type 200, solid material, stainless or creep-resistant steel

Sensor connection cable 4-wire, screened

M-BUS interface

External absolute pressure transducer 0-16 / 25 / 40 bara

8 digit remote counter, controlled by voltage-free contacts

Optoelectronic coupler outputs

Pulse input board

fault indication counters for energy and mass (volume)

additional counters for heat and mass (volume) only in combination with pulse-input board

Power supply 24 V DC / AC

DT 311P / DT 312 P version „precision“ (only available in combination with zero-balancing module)

Test certificate for 10 flow values (basis: pressure differential)

System test, commissioning and instruction by METRA service personnel

Metra Energie-Messtechnik GmbH
Am Neuen Rheinhafen 4, D - 67346 Speyer

Tel. +49 (0)6232 / 657 - 519
Fax. + 49 (0)6232 / 657 - 200

The purchaser should read the information and technical data contained in catalogues, brochures and other documentation like drawings and offers prior to taking possession and application of the product. The purchaser cannot derive claims against Metra and Metra staff on behalf of these data or additional services unless gross negligence or purpose can be alleged. Metra reserves the right to apply changes to their products – even to already ordered items - within appropriate and reasonable limits without preceding notice. All trademarks contained within this publication are proprietary to the respective firms. Metra and the Metra logo are trademarks of Metra. All rights reserved.