

Level Meter Innovation from Bopp & Reuther Messtechnik

Media independent Level measurement: MG1 series

- Fast reaction time of 0,5 sec
- Precise continuous level measurement and reliable point level detection combined in one device
- For liquids as well as powdery solids suitable
- No influences caused by tank / vessel internals
- Unmatched price/performance ratio

Technical Perfection
+
Favourable price

Description

The MG1 series uses TDR (Time Domain Reflectometry) technology: Energy optimized, high-frequency electromagnetic impulses, generated by the electronics, are propagated along the probe. When these impulses hit the surface of the media, part of the impulse energy is reflected back up the probe to the electronics. The level is calculated from the time difference between the impulse sent and the impulses reflected. The sensor can output the analysed level as a continuous measurement reading through its current output, and it can convert the one value into a freely positionable switching output signal. TDR-Sensors are also known as Guided Radars or Guided Wave Radars (GWR).

Application Areas

The innovative TDR technology enables direct, precise and highly reliable continuous level measurement as well as point level detection in almost every liquid and solids –independent of changing process conditions (such as density, conductivity, temperature, pressure, vapour and turbulence). It is suitable for all types of process and storage tank applications and has an exceptional performance in media with low dielectric constant (i.e. low reflectivity) such as oils and hydrocarbons.

Technical Data

Accuracy	± 3mm or 0,03% of measured distance*
Repeatability	<2mm*
Resolution	<1mm*
Ambient temperature	-25°C to +80°C
Application temperature	Single rod / wire rope probe: -40°C to +150°C Coaxial probe EPDM o-ring: -40°C to +130°C Coaxial probe FKM (viton) o-ring: -15°C to +150°C
Process connection	Tthreads G 3/4A, ¾" NPT (wrench size 32mm)
Power supply	12 to 30 VDC (reverse polarity protected)
Outputs	Analog: 4...20mA (active) Switch: DC PNP (active)
Materials (wet)	Single rod probe: 1.4404 / 316L, Peek, Ø 6mm Wire rope probe: 1.4404 / 316L, Peek, Ø 4mm Coaxial probe: 1.4404 / 316L, Peek, Ø 17,2mm and o-ring: EPDM or FKM (Viton)
Protection class	IP 68, NEMA6P (housing)

*Reference conditions: dielectric constant $\epsilon_r=80$, water surface, tank Ø1m, DN200 metal flange



Measuring Ranges

Type	Measuring range
MG1-E Single rod probe	100 – 3.000mm
MG1-S Wire rope probe	1.000 – 20.000mm
MG1-C Coaxial probe	100 – 6.000mm

More advantages of MG1 series

... based on the proven principle

- fully modular probe design, i.e. the probe types are interchangeable without any special tools or welding
- complete galvanic insulation of device electronics from its inputs/outputs and the tank potential (no problems with electrochemical corrosion protection)
- highly robust measurement due to 4-wire design and innovative signal analysis and disturbance signal suppression

Probe length and measuring range

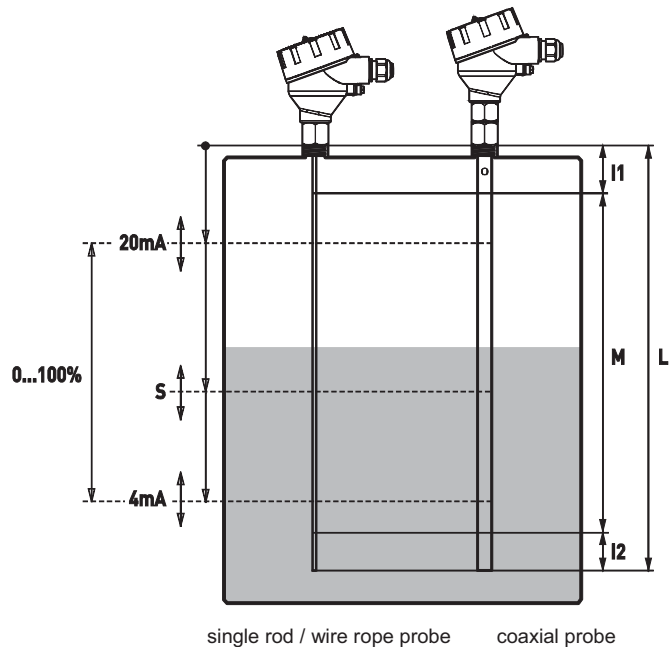

L1: inactive area	MG1-E / MG1-S	: 50 ... 80mm*
	MG1-C	: 30 ... 50mm*
L2: inactive area	MG1-E / MG1-S / MG1-C	: 10 ... 50mm*
M:	measuring area	
L:	probe length	
S:	switch point	

* depending on the ϵ_r of the media from 2 ... 80

... no installation restrictions

- the MG1 series has almost no installation restrictions
- it can be mounted in small tanks, tall and narrow nozzles and it measures precisely even with difficult tank geometries or close to interfering structures
- the MG1 series is also especially suitable in bypass chambers and stilling wells

Mounting

